

# Hand pallet truck 2.3 ton

## BT pro lifter



# Hand pallet truck

Truck specifications					LHM230P
Identification	1.1	Manufacturer			BT
	1.2	Manufacturer's type designation			LHM230P
	1.4	Operator type			Hand
	1.5	Load capacity/rated load	Q(t)	kg	2300
	1.6	Load centre distance	c	mm	600
	1.8	Load distance, front axle to fork face	x	mm	945 <sup>1)</sup>
	1.9	Wheelbase	y	mm	1170 <sup>1)</sup>
Weight	2.1	Service weight		kg	75
	2.2	Axle load, with load, drive/castor/fork wheel		kg	375/805
	2.3	Axle load, without load, drive/castor/fork wheel		kg	20/10
Wheels	3.1	Steer/fork wheels: Powerthane (Po), Steel (S), Nylon (N), Polyurethane (P), Rubber (R), Rubber antistatic (Ra)			Po, Ra / Po, S, N, P
	3.2	Wheel size, front			175x60
	3.3	Wheel size, rear			85x100 / 85x75 <sup>2)</sup>
	3.5	Wheels, number front/rear (x=driven wheels)			2/2 or 2/4 <sup>2)</sup>
	3.6	Track width, front	b <sub>10</sub>	mm	148
	3.7	Track width, rear	b <sub>11</sub>	mm	364
	Dimensions	4.4	Lift	h <sub>3</sub>	mm
		Lift height	h <sub>23</sub>	mm	200
4.9		Height of tiller in drive position, min./max.	h <sub>14</sub>	mm	1220
4.15		Height, lowered	h <sub>13</sub>	mm	85
4.19		Overall length	l <sub>1</sub>	mm	1575
4.20		Length to face of forks	l <sub>2</sub>	mm	415
4.21		Overall width	b <sub>1</sub> /b <sub>2</sub>	mm	520/685 <sup>3)</sup>
4.22		Fork dimensions	s/e/l	mm	45/156/1150 <sup>4)</sup>
4.25		Width over forks	b <sub>5</sub>	mm	520/685 <sup>3)</sup>
4.32		Ground clearance, centre of wheelbase	m <sub>2</sub>	mm	40
4.33		Aisle width for pallets 1000 x 1200 crossways	A <sub>st</sub>	mm	1525 <sup>1)</sup>
4.34		Aisle width for pallets 800 x 1200 lengthways	A <sub>st</sub>	mm	1725 <sup>1)</sup>
4.35		Turning radius	W <sub>a</sub>	mm	1370 <sup>1)</sup>

1) Distance with forks raised

2) Single wheel / Boggie wheel

3) Other widths available on request

4) Other fork length available: 810/910/1000/1070/1220

All data are based on table configuration. Other configurations may give other values.

Truck performance and dimensions are nominal and subject to tolerances.

Specifications are subject to change without notice.

# Dimensional drawings

# BT pro lifter

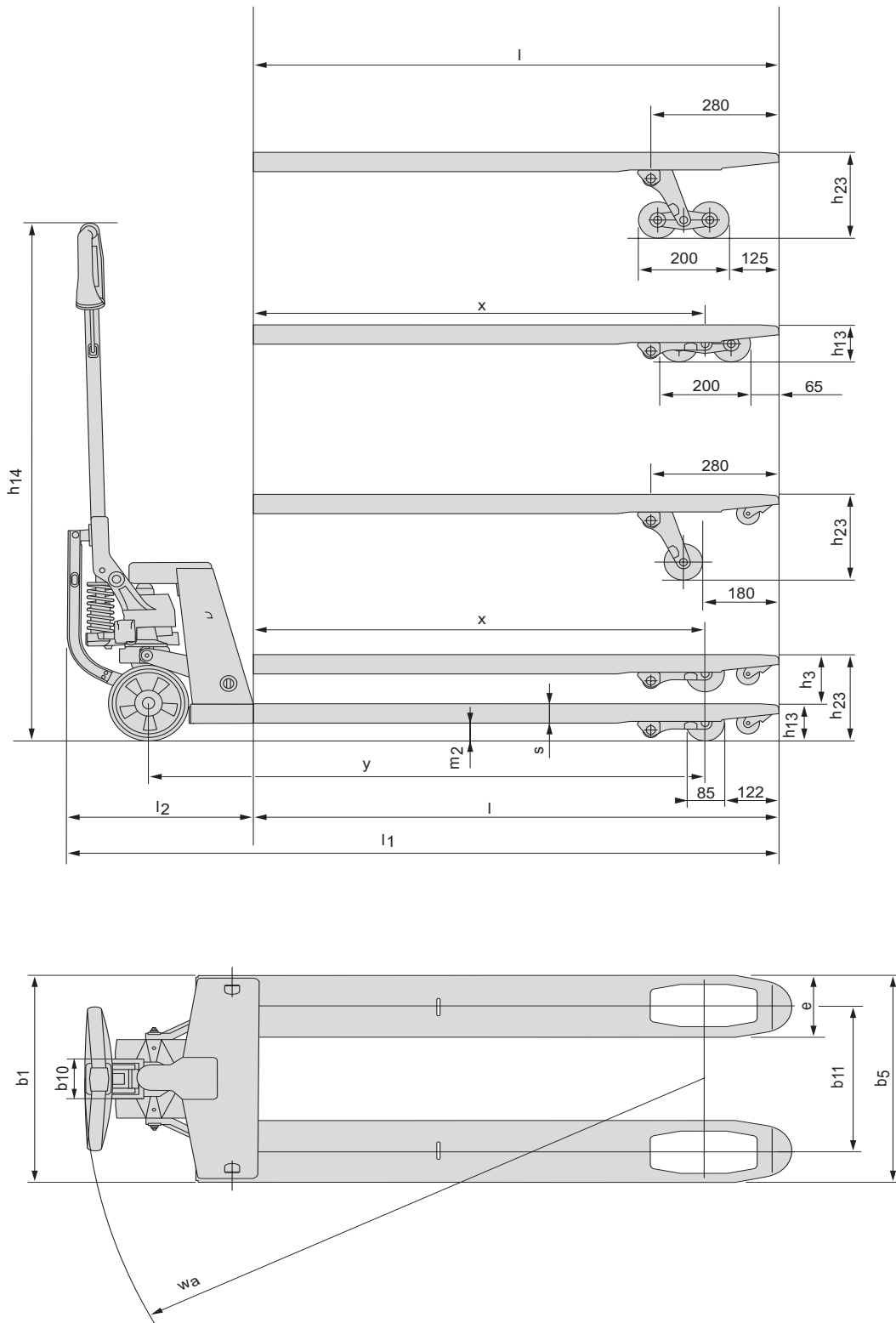

---

## Truck features:

- Unique option for heavy duty applications an easy positioning.
- A connection between the tow bar and the steering wheels transfers the force from the pump stroke to the wheel to get the truck started.
- The Quick Lift is the best ergonomic choice, because the number of pump strokes are reduced.
- With over load limitation you protect the truck floors from being over loaded.
- This unique Pro Lifter pump can be assembled on any length or width on a LHM230 including reel drum handling.
- Intended for indoor applications.
- This product has been environmentally declared.

